

LMS-Q560

The **RIEGL® LMS-Q560** is a revolutionary 2D laser scanner applying the latest state-of-the-art digital signal processing technique which meets the most challenging requirements in airborne laser scanning.

The **RIEGL LMS-Q560** gives access to detailed target parameters by digitizing the echo signal online during data acquisition, and subsequent off-line waveform analysis. This method is especially valuable when dealing with difficult tasks, such as canopy height investigation or target classification. The operational parameters of the **RIEGL LMS-Q560** can be configured to cover a wide field of applications. Comprehensive interface features support smooth integration of the instrument into complete airborne scanning systems.

The instrument makes use of the time-of-flight distance measurement principle of nanosecond infrared pulses. Fast opto-mechanical beam scanning provides absolutely linear, unidirectional and parallel scan lines. The instrument is extremely rugged, therefore ideally suited for the installation on aircraft. Also, it is compact and lightweight enough to be installed in small twin- or single-engine planes, helicopters or UAVs. The instrument needs only one power supply and GPS timing signals to provide online monitoring data while logging the precisely time-stamped and digitized echo signal data to the rugged **RIEGL Data Recorder**.

- **full waveform analysis for unlimited number of target echoes**
- **high laser pulse repetition rate up to 240 kHz**
- **high mean measurement rate up to 160 000 measurements/sec**
- **high ranging accuracy of 20 mm**
- **interface for smooth integration of GPS**
- **eye safe for operation at any altitude**
- **parallel scan lines**
- **compact and rugged design, single power supply**
- **wide operating temperature range**

Topography & Mining
Corridor Mapping
City Modeling
Mapping of Lakesides & River Banks
Agriculture & Forestry
Target Classification
Glacier & Snowfield Mapping
Power Lines

visit our website www.riegl.com

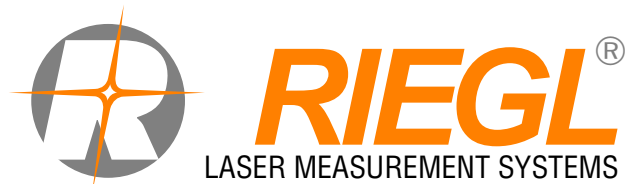

Echo Digitization of the RIEGL LMS-Q560

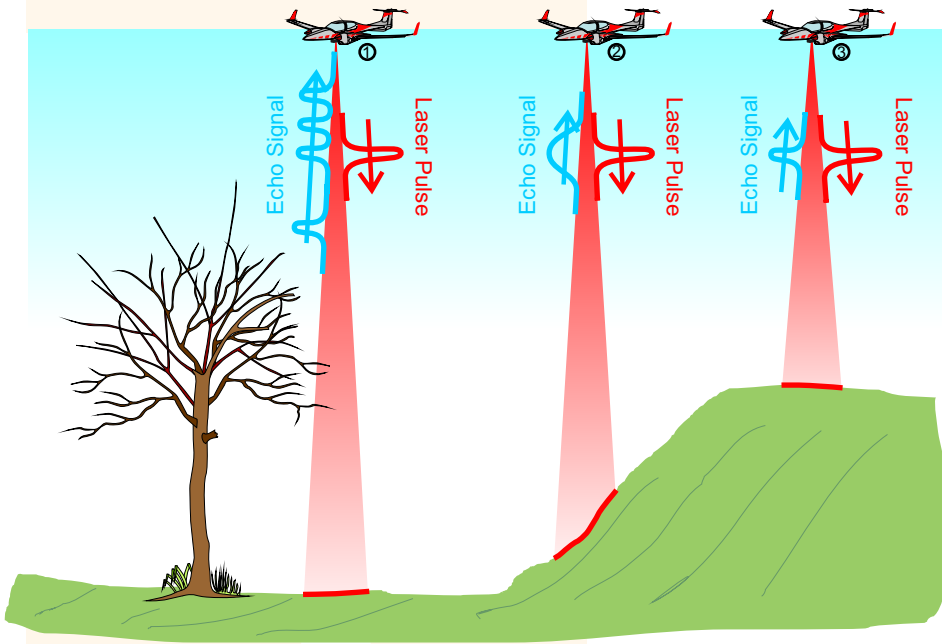

Fig. 1 Echo signals resulting from different types of targets

In situation 1, the laser pulse hits the canopy first and causes three distinct echo pulses. A fraction of the laser pulse also hits the ground giving rise to another echo pulse. In situation 2, the laser beam is reflected from a flat surface at a small angle of incidence yielding an extended echo pulse width. In situation 3, the pulse is simply reflected by a flat surface at perpendicular incidence resulting in one single echo pulse with a shape identical to the transmitted laser pulse.

The digitization feature of the RIEGL LMS-Q560 enables the user to extract most comprehensive information from the echo signals. Figure 1 illustrates a measurement situation where 3 laser measurements are taken on different types of targets. The red pulses symbolize the laser signals travelling towards the target with the speed of light. When the signal interacts with the diffusely reflecting target surface, a fraction of the transmitted signal is reflected towards the laser instrument, indicated by the blue signals.

In situation 1, the laser pulse hits the canopy first and causes three distinct echo pulses. A fraction of the laser pulse also hits the ground giving rise to another echo pulse.

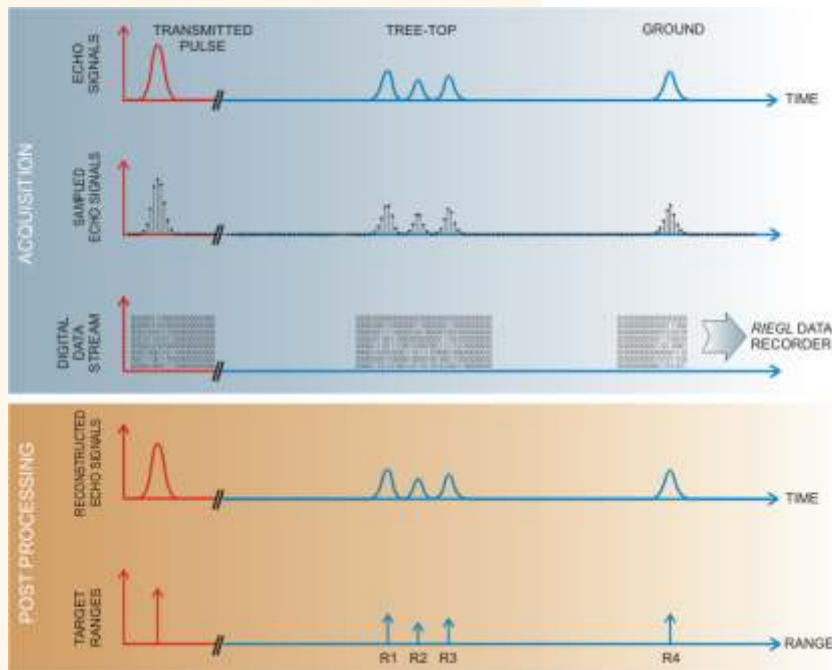

Fig. 2 Data acquisition and post processing

The upper line of the acquisition diagram shows the analog signals: the first (red) pulse relates to a fraction of the laser transmitter pulse, and the next 3 (blue) pulses correspond to the reflections by the branches of the tree; the last pulse corresponds to the ground reflection.

This analog echo signal is sampled at constant time intervals (middle line) and is, in the following, analog-to-digital converted, resulting in a digital data stream (bottom line of the acquisition section). This data stream is stored in the RIEGL Data Recorder for subsequent off-line post processing, as indicated in the post-processing section of the diagram.

Based upon RIEGL's long-standing expertise and experience in designing, manufacturing and marketing digitizing laser rangefinders for

challenging industrial and surveying applications, and due to the careful design of the analog and digital front-end electronics, the LMS-Q560 records the complete information of the echo signal over a wide dynamic range. Thus, in post-processing the signal can be perfectly reconstructed and analyzed in detail to precisely derive target distance, target type, and other parameters.

Maximum Measurement Range & Point Density for RIEGL LMS-Q560

PRR = 240 kHz

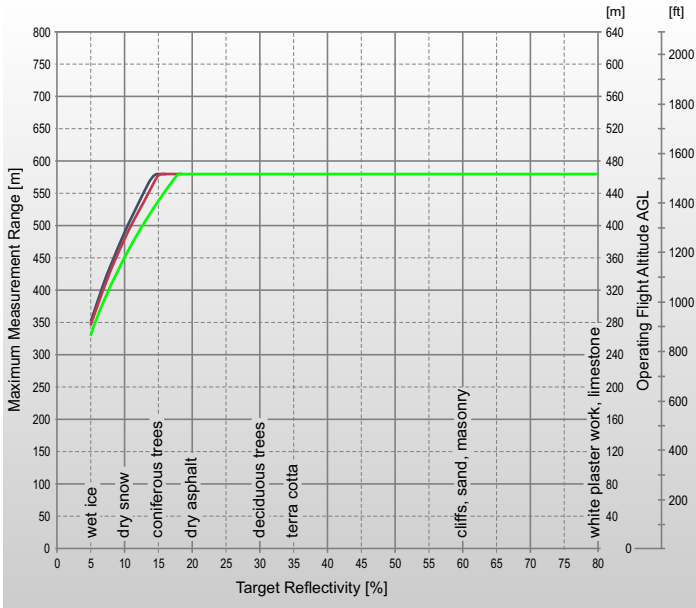

PRR = 240 kHz

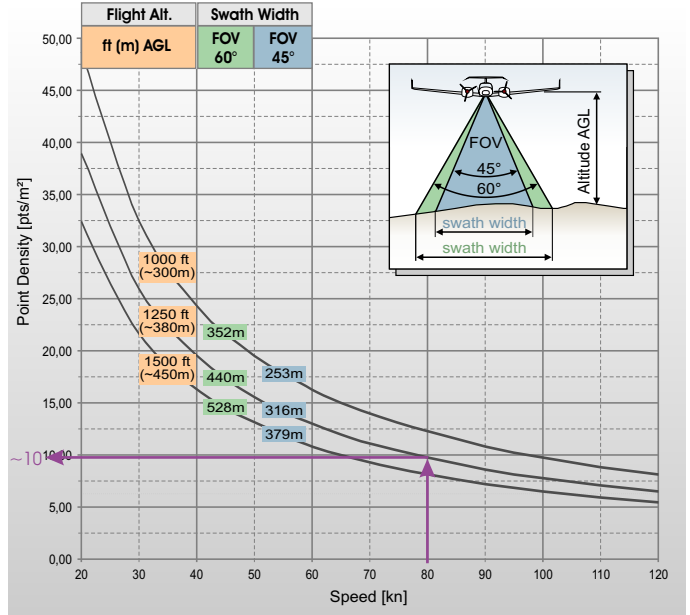

For the Operating Flight Altitude AGL, the following conditions are assumed

- target size laser footprint
- average ambient brightness
- scan angle 60°
- roll angle +/- 6°

PRR = 180 kHz

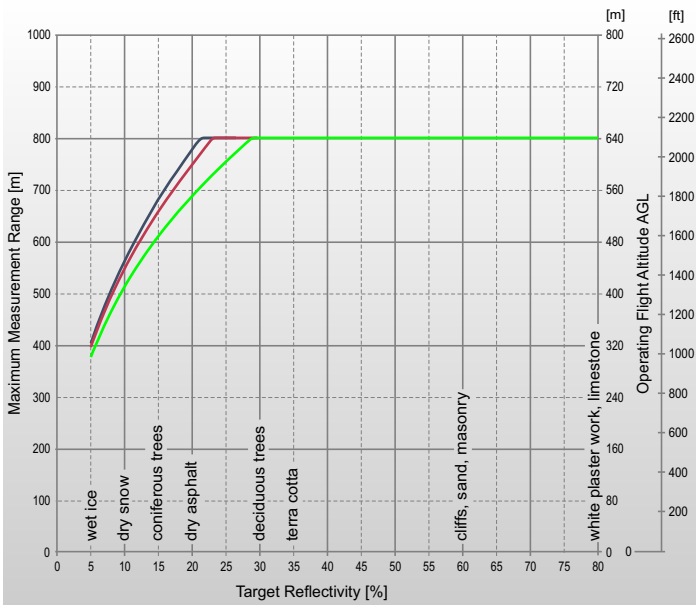

PRR = 180 kHz

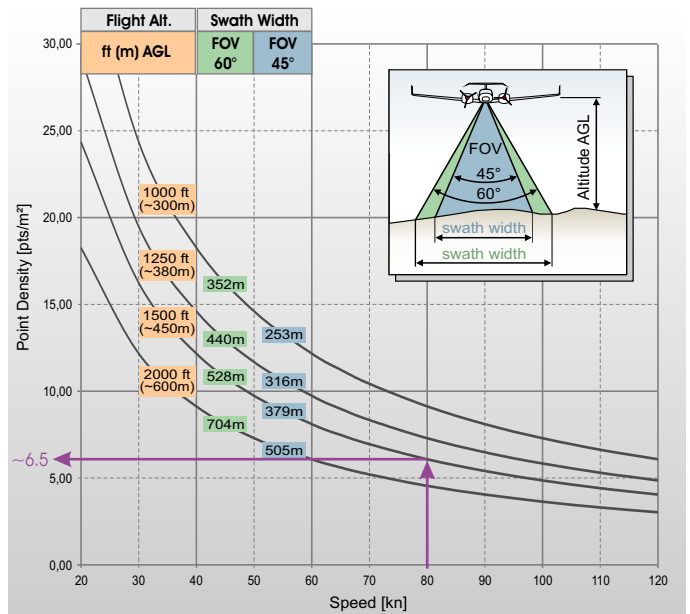

Maximum Measurement Range & Point Density for RIEGL LMS-Q560

PRR = 100 kHz

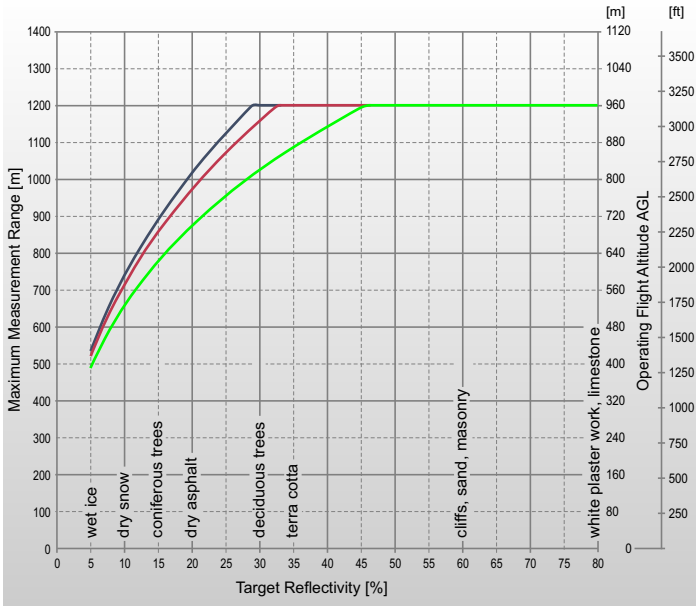

PRR = 100 kHz

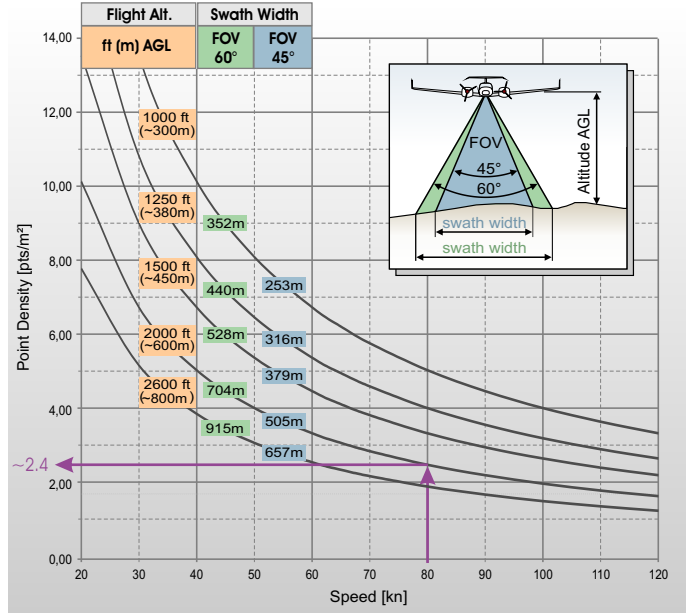

For the Operating Flight Altitude AGL, the following conditions are assumed

- target size laser footprint
- average ambient brightness
- scan angle 60°
- roll angle +/- 6°

PRR = 50 kHz

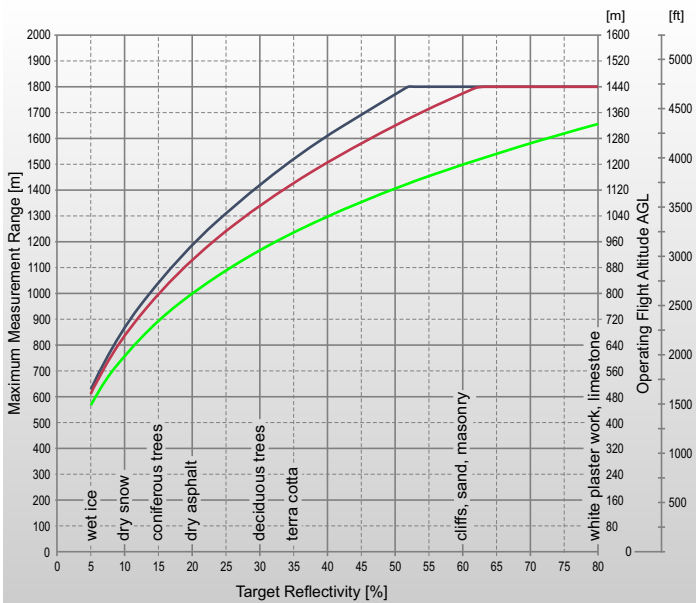

PRR = 50 kHz

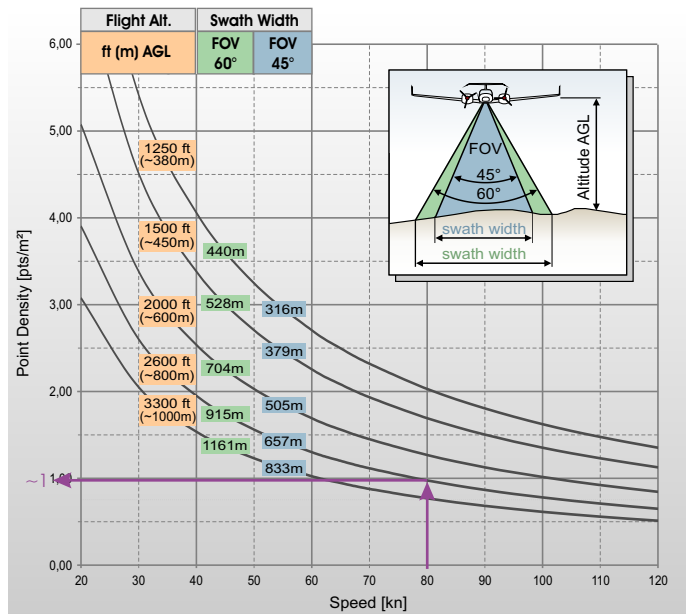

⊕ origin of scanner's local coordinate system

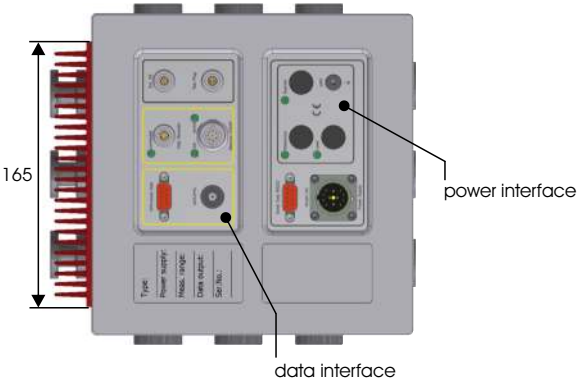

rear view

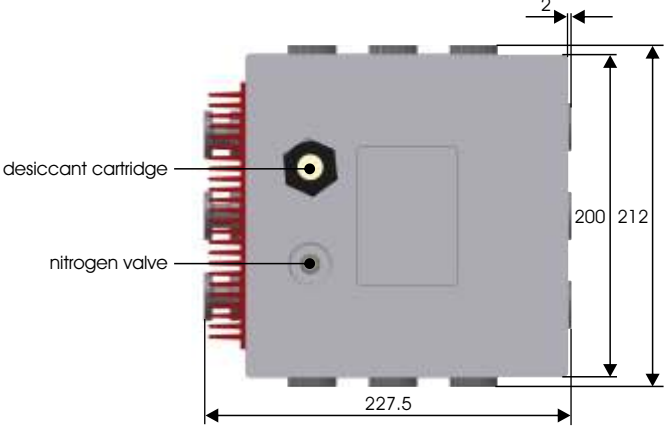
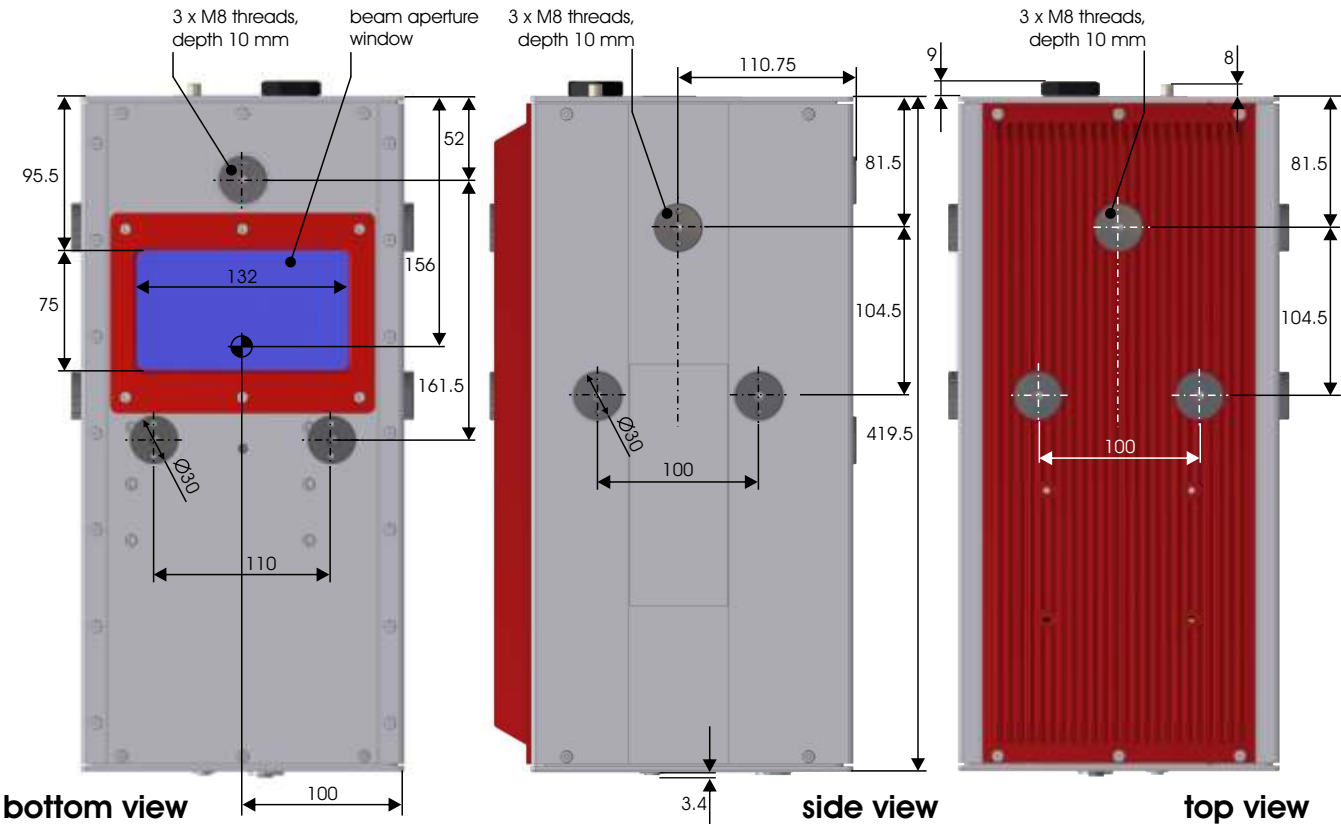

front view

all dimensions in mm

Technical Data RIEGL LMS-Q560

Laser Product Classification

Class 1 Laser Product according to IEC60825-1:2007

The following clause applies for instruments delivered into the United States:
Complies with 21 CFR 1040.10 and 1040.11 except for deviations pursuant
to Laser Notice No. 50, dated June 24, 2007.



Range Measurement Performance

as a function of PRR and target reflectivity

Laser Pulse Repetition Rate	50 kHz	100 kHz	180 kHz	200 kHz	240 kHz
max. Unambiguous Measurement Range ¹⁾					
natural target 20 %	1200 m	1000 m	780 m	700 m	580 m
natural target 60 %	1800 m	1200 m	800 m	700 m	580 m
max. Operating Flight Altitude AGL ²⁾	1000 m	800 m	600 m	550 m	450 m
	3300 ft	2600 ft	2000 ft	1800 ft	1500 ft

1) The following conditions are assumed: • target is larger than the footprint of the laser beam • average ambient brightness
• perpendicular angle of incidence • visibility 23 km

2) Reflectivity 20 %, max. scan angle 60°, additional roll angle +/- 5°

Minimum Range

30 m

Accuracy³⁾⁴⁾

20 mm

Precision⁵⁾⁵⁾

10 mm

Laser Pulse Repetition Rate⁶⁾

up to 240 000 Hz

Effective Measurement Rate

up to 120 kHz @ 45° scan angle
to 160 kHz @ 60° scan angle

Laser Wavelength

near infrared

Laser Beam Divergence⁷⁾

0.5 mrad

Number of Targets per Pulse

digitized waveform processing: unlimited⁸⁾

online monitoring data output: first pulse or last pulse

Scanner Performance

Scanning Mechanism

rotating polygon mirror

Scan Pattern

parallel scan lines

Scan Angle Range

$\pm 22.5^\circ = 45^\circ$ total ($\pm 30^\circ = 60^\circ$ total⁹⁾)

Scan Speed

10 - 160 lines/sec

Angular Step Width⁶⁾

0.004° (for PRR in excess of 100 000 Hz¹⁰⁾)

between consecutive laser shots

Angle Measurement Resolution

0.001°

Scan Sync

option for synchronizing scan lines to external timing signal

3) Standard deviation one sigma @ 250 m range under RIEGL test conditions.

4) Accuracy is the degree of conformity of a measured quantity to its actual (true) value.

5) Precision, also called reproducibility or repeatability, is the degree to which further measurements show the same result.

6) User selectable

7) 0.5 mrad correspond to 50 cm increase of beam width per 1000 m distance

8) Practically limited only by the maximum data rate allowed for the RIEGL Data Recorder

9) Up to 60° with 90% of maximum measurement range

10) Minimum angle step width increasing linearly to 0.008° @ 50000 Hz laser pulse repetition rate

Intensity Measurement

For each echo signal, high-resolution 16-bit intensity information is provided which can be used for target discrimination and/or identification/classification.

Data Interfaces

Configuration

TCP/IP Ethernet (10/100 MBit), RS232 (19.2 kBd)

Monitoring Data Output

TCP/IP Ethernet (10/100 MBit)

Digitized Data Output

high speed serial data link to RIEGL Data Recorder

GPS-System

serial RS232 interface, TTL input for 1pps synchronization pulse, accepts different data formats for GPS-time information

General Technical Data

Power Supply

18 - 32 VDC

Current Consumption

approx. 5 A @ 24 VDC

Main Dimensions (L x W x H)

420 x 212 x 228 mm

Weight

16 kg

Protection Class

IP54

Max. Flight Altitude (operating)

16 500 ft (5 000 m) above MSL

Max. Flight Altitude (not operating)

18 000 ft (5 500 m) above MSL

Temperature Range

0°C up to +40°C (operation) / -15°C up to +50°C (storage)

Mounting of IMU-Sensor

steel thread inserts on the top and on the sides of the laser scanner, rigidly connected to the inner structure of the scanning mechanism



RIEGL[®]
LASER MEASUREMENT SYSTEMS

RIEGL Laser Measurement Systems GmbH, 3580 Horn, Austria
Tel.: +43-2982-4211, Fax: +43-2982-4210, E-mail: office@riegl.co.at

RIEGL USA Inc., Orlando, Florida 32819, USA
Tel.: +1-407-248-9927, Fax: +1-407-248-2636, E-mail: info@rieglusa.com

RIEGL Japan Ltd., Tokyo 1640013, Japan
Tel.: +81-3-3382-7340, Fax: +81-3-3382-5843, E-mail: info@riegl-japan.co.jp

www.riegl.com